



# GREEN TVET

SOLAR SYSTEM AWARENESS GUIDE



## **Executive Summary**

Solar energy is a clean source of energy that is slowly taking shape in Africa and Kenya as it continues to expand. In the quest of the Salesians of Don Bosco to protect and conserve the environment, the Green TVET through the Green specialist and green facilitators seeks to create awareness to the students in our TVET centers on the solar system through this awareness guide.

This guide seeks to create awareness on the basics of the solar system: how it works and the types of solar PV system (on grid and off grid PV systems, solar energy and the social economic opportunities especially for the youth and women in an effort to curb unemployment, reduce respiratory and cognitive disorders, guide the students on the various solar appliances such as water pumps, lanterns, dryers and the Pico solar systems, operation and maintenance of the solar system including troubleshooting and the relationship between solar system, climate change and environmental degradation and the solar system as a renewable source of energy.

This guides aims to empower the students by giving them in-depth knowledge of the solar system, the advantages and disadvantages to enable them curve a niche for themselves in this market. It is a fresh market with many opportunities especially for the youth who are in our centers.

### **Purpose**

The purpose of this awareness guide is to create awareness to the students in the TVET Centers as champions of Environmental protection for sustainable development.

It should guide the students on the relevant steps to take when it comes to solar energy.

It is meant to change the daily activities of the students through small steps leading to a change of attitudes in relation to management, protection and use of the natural resources like the sun.

## Goal

The overall goal is to capacity build the students through awareness creation campaigns on solar energy.

## Objectives

1. To create awareness on the basics of solar.
2. To create awareness on solar energy and socio-economic opportunities.
3. To create awareness on the various solar appliances which can replace the electric ones
4. To guide the students on the operation and maintenance of the solar system including troubleshooting.
5. To create awareness on the direct relationship between climate change, environmental degradation and solar energy.

## Scope

This guide will form a foundational basis in solar system in our TVET Centers and neighboring communities as we intend to bring on board even students from primary and high schools and training the participants on different core topics including:

1. Basics of Solar
2. Solar energy and socio-economic opportunities
3. Solar appliances
4. Operation and maintenance of solar system
5. Solar system as a renewable source of energy in relation to climate change and environmental degradation

#### Target audience

1. Students in our TVET Centers
2. Staff members in the TVET Centers
3. Students from other educational institutions
4. Community members
5. Government
6. Business community
7. Parents
8. Environmental enthusiasts

#### Affirmation

It is our intention as the Green TVET project of the Global Program to push for the preservation, conservation, protection and management of the environment. There is no planet B for the future generations. Time for action is now

## **Table of Content**

Executive

Summary.....  
..... 2

Chapter 1: Introduction to the Solar System	7
Chapter 2: Basics of the Solar System	15
Chapter 3: Solar Energy and Socio-economic opportunities	31
Chapter 4: Solar Appliances	34
Chapter 5: Operation and Maintenance of the Solar System	39
Chapter 6: Climate Change and the Solar System	41
Conclusion	42
References	43

## **Chapter 1: Introduction to Solar Energy**

Renewable and nonrenewable resources are energy sources that human society uses to function on a daily basis. The difference between these two types of resources is that renewable resources can naturally replenish themselves while nonrenewable resources cannot. This means that nonrenewable resources are limited in supply and cannot be used sustainably.

There are four major types of nonrenewable resources and they include oil, natural gas, coal, and nuclear energy. Oil, natural gas, and coal are collectively called fossil fuels. Fossil fuels were formed within the Earth from dead plants and animals over millions of years. They are found in underground layers of rock and sediment. Pressure and heat worked together to transform the plant and animal remains into crude oil (also known as petroleum), coal, and natural gas.

The energy in the plant and animal remains originally came from the sun through the process of photosynthesis. Solar energy is stored in plant tissues which animals then consume adding the energy to their own bodies. When fossil fuels are burned, this trapped energy is released.

Crude oil is a liquid fossil fuel that is used mostly to produce gasoline and diesel fuel for vehicles and for the manufacturing of plastics. It is found in rocks below Earth's surface and is pumped out through wells.

Natural gas is widely used for cooking and for heating homes. It consists mostly of methane and is found near oil deposits below Earth's surface. Natural gas can be pumped out through the same wells used for extracting crude oil.

Coal is a solid fossil fuel that is used for heating homes and generating power plants. It is found in fossilized swamps that have been buried beneath layers of sediment. Since coal is solid, it cannot be extracted in the same manner as crude oil or natural gas, it must be dug up from the ground.

Nuclear energy comes from radioactive elements mainly uranium which is extracted from mined ore and then refined into fuel.

Unfortunately, the human society is dependent on nonrenewable resources as its primary source of energy. Approximately 80% of the total amount of energy used globally each year comes from fossil fuels. We depend on fossil fuels because they are energy-rich and relatively cheap to process. However, a major problem with fossil fuels aside from them being in limited supply is that burning them releases carbon dioxide into the atmosphere. The rising levels of heat trapping carbon dioxide in the atmosphere is the main cause of global warming.

Disadvantages of non-renewable energy sources

1. Non-renewable energies lead to high levels of pollution.

If we were to take only the subsidized figures from the non-renewable energy industry, the fossil fuels we consume represent 28% of the global greenhouse gas emissions released each year. Eliminating this issue by itself could reduce the premature deaths linked to pollution by almost 50%.

2. Fossil fuels will not be available forever because they are non-renewable

Although the estimates for fossil fuel availability have been changing consistently over the past 30 years, nonrenewable resources will become unavailable in the future. Developing alternative energies allows us to create a safety net for tomorrow's generation. Because many of our solar, wind and

biogas energies rely on manufacturing processes that include natural gas and oil. It is up to us to find a balance in our consumption patterns.

As of 2020, most experts believe that we have between 40 to 80 years of non-renewable energy availability.

3. Non-renewable products can become the foundation of political conflict.

Countries go to war frequently over access to needed resources. Our economy's reliance on nonrenewable energy creates the foundation for future conflicts. It is not unusual to hear government critics suggest that military action should be taken to gain control over oil wells, natural gas deposits, and similar resources.

Our economy already deals with the impact of artificial scarcity through the export market for non-renewable energy. The extra money that we pay to have access to fossil fuels could be put into investment funds that lead us towards more biogas, solar and wind systems.

4. Fossil fuel combustion is dangerous to our health.

When coal fuels burn, they release particulates into the atmosphere unless a filter captures them. These small particles increase the risk of cancer, heart attacks, and strokes when people receive exposure to them.

Breathing in the pollution from non-renewable energies leads respiratory diseases like asthma or Chronic Obstructive Pulmonary Disease (COPD).

Sulphur oxide in the atmosphere mixes with water when it rains forming acidic rain, which is harmful to all living organisms.

We cannot remove this disadvantage of non-renewable energy immediately because our manufacturing processes require fossil fuels. Sustainable practices

can get us to a net-zero solution but we will always have a certain level of risk to consider.

5. Plants and animals face the same problems humans do with non-renewables.

Although some plants thrive in environments that have significant carbon dioxide levels, most flora and fauna require the same healthy processes that humans do to support good health. When we expose living organisms to fossil fuels in unnatural ways, their health is almost immediately put at risk.

6. Non-renewable energy refinement destroys the environment.

When we make improvements to our support network for non-renewable energy, we are also increasing the adverse risks that the environment faces each day.

Establishing manufacturing hubs, refinement systems, and transportation methods all require investments from fossil fuels that are at a much higher level than the structures used for items like biogas, solar and wind. All of these activities enhance the effect that emissions have on our atmosphere.

7. Some non-renewables have limited availability in today's market.

Only five countries are currently responsible for 75% of the worldwide consumption of coal products. India, China, Russia, Japan, and the United States all support massive non-renewable energy industries, and they are some of the world's largest polluters of greenhouse gases. The bituminous coal that we use for energy and metals manufacturing is made of 85% carbon, making it a potentially significant contributor to climate change.

We also have higher levels of sulfur, water vapor, and hydrogen in our atmosphere because of the mining, extracting, and refining activities that take place in the non-renewable industry.

8. It is too cheap for us to walk away from this resource.

We have spent over a century developing the infrastructure needed to consume fossil fuels in meaningful ways. Some of the technologies that we use today come from ideas that are over 300 years old because of the ways that early societies consumed items like whale oil.

Trying to make a switch to something that is more expensive than non-renewable energy is not feasible in some countries right now.

9. The mining of non-renewable energy and the by-products they leave behind causes damage to the environment.

Advantages of renewable energy sources

1. Renewable energy replenishes itself naturally.

Renewable energy technologies use resources straight from the environment to generate power. These energy sources include biomass, sunshine, wind and tides to name some of the popular options. Renewable resources do not run out, which cannot be said for many types of fossil fuels as we use fossil fuel resources, they will be increasingly difficult to obtain, likely driving up both the cost and environmental impact of extraction.

2. Maintenance requirements are lower

In most cases, renewable energy technologies require less overall maintenance than generators that use traditional fuel sources.

This is because generating technology like solar panels and wind turbines either have few or no moving parts or do not rely on flammable, combustible fuel

sources to operate. Fewer maintenance requirements translate to more time and money saved.

### 3. Renewables save money

Using renewable energy can help you save money long term. Not only will you save on maintenance costs, but on operating costs as well. When you are using a technology that generates power from the sun, wind, steam, or natural processes, you do not have to pay to refuel.

The amount of money you will save using renewable energy can vary depending on a number of factors, including the technology. In most cases, transitioning to renewable energy means anywhere from hundreds to thousands of dollars in savings.

### 4. Renewable energy has numerous health and environmental benefits

Renewable energy generation sources emit little to no greenhouse gases or pollutants into the air. This means a smaller carbon footprint and an overall positive impact on the natural environment. During the combustion process, fossil fuels emit high amounts of greenhouse gases, which have been proven to exacerbate the rise of global temperatures and frequency of extreme weather events.

The use of fossil fuels not only emits greenhouse gases but other harmful pollutants as well that lead to respiratory and cardiac health issues. With renewable energy, you are helping decrease the prevalence of these pollutants and contributing to an overall healthier atmosphere.

### 5. Renewables lower reliance on foreign energy sources

With renewable energy technologies, you can produce energy locally. The more renewable energy you are using for your power needs, the less you will rely on imported energy.

When a learning institution switches to solar, power it not only saves energy and money, but also it is also a valuable teaching aid to the youths, especially in these current climates where non-renewable sources of energy are depleting.

Learning institutions consume a large amount of energy due to the number of appliances they use – lights, computers and phones all add to the energy used and this can be cut through solar systems. Africa has unique potential to scale up energy access to modernize agriculture; rekindle industrialization; increase jobs; and reduce poverty and reduce exclusion.

Due to the geographic landscape of African countries, particularly rural communities, access to the national grid is very difficult and expensive. Cost-effective renewable energy therefore becomes the most effective solution to rural electrification in Africa. This solution unleashes the productive capacity of around two-thirds of the population of many African.

Access to electricity is fundamental to sustainable development and necessary for basic household activities. The lack of electricity can hamper productivity, limit opportunities for income generation and inhibit the ability to improve living conditions. Nearly 1.1 billion people worldwide are still living without electricity and another one billion are connected to unreliable and unstable electricity grids. While significant progress has been made in recent years to increase grid electrification in countries within Africa, projections suggest that by 2030 nearly 780 million people could still be off-grid.

New and sustainable approaches to providing electricity that transcend the established norms are required, especially if we are to achieve the Sustainable Development Goal of universal access to affordable, reliable and modern energy services by 2030.

## **Chapter 2: Basics of Solar**

The sun does not just provide warmth and light, it is a source of energy.

Solar energy (or solar power) is the energy we generate from sunlight. Through a process known as the photovoltaic effect, we can convert energy from the sun's rays into electricity that can power our TVs, refrigerators, lights and other appliances.

What are the parts of a solar energy system?

There are other key components to a solar system aside from the panels themselves.

To generate your own energy, you need a complete solar power system. The essential components:

- Solar panels: to capture energy from the sun
- An inverter: to convert that energy to a format that can power your appliances
- Racking: the foundation on which you mount your system

You also need a method to store the energy generated by the panels. If you have access to power lines, this does not require additional equipment. It can simply be fed into the utility grid and used later.

However, if you are off the grid, you will need additional parts:

- Batteries, to store the energy you generate
- Charge controller, to control the rate at which batteries charge from solar

These are connected by smaller components like wiring, fuses, and disconnects.

You can also add equipment to monitor your system's output online, which helps troubleshoot any issues with shading or defective equipment.

#### Powering the home with the batteries

When desired, the charge controller will provide power to the home from the batteries. The batteries will provide continuous power up to their rated discharge level or until when they are cut off by the charge controller. To prevent over-discharging, the charge controller will cut off the batteries if they reach their maximum depth-of-discharge level. Most lithium-ion batteries will reach that level when the voltage produced by the battery's cells drops to 3.0 V per cell. If the batteries charge is used up, the home will automatically be switched to grid power.

#### How the solar energy storage system works in blackouts

In a blackout, the system is isolated from the grid to prevent electrical discharge into the grid during times when the power lines may be undergoing maintenance or are damaged. During the day, the solar panels will charge the batteries.

While the batteries are charging, the system's inverter has a special circuit that allows power to be drawn from the solar panels to power selected circuits. The amount of power available is typically not enough to entirely power the home.

The amount of power available depends on the inverter

The amount of power available from a solar energy storage system depends on the type of inverter used.

High-end inverters connect directly to circuits in the home that are designated to receive power during blackouts. Some lower-powered inverters simply offer outlets that you can connect an extension cord.

How to size the batteries in a solar energy storage system

As a general rule of thumb, it is better to have more battery capacity than you need to meet the home's power needs. The faster you discharge batteries, the faster they wear out. If you have enough battery capacity such that regular usage only discharges the battery bank by 30 – 50% of the battery bank's capacity, this helps ensure long battery life and gives the homeowner an emergency power reserve should they need it.

Common Solar Battery Types

1. Lithium Ion

For the most reliable lifespan, the best choice for your home battery would be Lithium ion. Majority of new home battery storage uses this technology, as they have a longer lifespan.

Lithium ion batteries are also more compact, although they are more expensive compared to lead acid batteries.

## 2. Lead acid

Lead acid batteries have been used for decades and are one of the cheapest varieties in home energy storage for off-grid power systems. The downfall to buying this type of technology is that it is becoming outdated.

### Solar energy battery disposal (pollution)

Solar energy is praised as one of the greenest renewable energy sources for commercial and residential properties. Property owners are quickly making the switch to solar energy in order to reduce their impact on the environment and save money.

### The Lifespan of Solar Batteries

Solar batteries can last a long time, ranging from 5 to 15 years. The true lifespan however depends on the battery itself. The battery's manufacturer will provide a warranty that accounts for the lifetime and total cycles (charging fully to empty).

### Recycling Solar Batteries (managing e-waste)

In general, when it comes to batteries, regardless of size, there is a way to recycle the components. In fact, most areas have their own designated recycling facility. Options range from waste management facilities and recycling plants to a designated storefront with a licensed decommissioning professional.

There are a few different types of batteries on the market, all of which are recyclable! Some types of batteries may be more difficult to recycle than others; nonetheless, recycling attempts are made. Examples of different types of batteries can be found below:

### Lithium-Ion Batteries

- Difficult to recycle
- Approximately 5% of Lithium-ion batteries are recycled
- Longest lasting
- Lightweight
- Mostly used in solar installations

### Lead-Acid Batteries

- The most common type of battery
- Easily recycled
- 90-98% of batteries recycled are lead acid
- Reliable
- Long lasting

The best way to recycle solar batteries is either through a licensed professional or by returning the battery to the manufacturer through the extended producer responsibility process.

What are the pros and cons of solar power?

Pros

- **Renewable:** Sunlight is an infinite resource. It is not like oil, which we remove from the Earth and spend when we use it. The sun's rays can be harvested for energy repeatedly without depleting the source.

- **Lower Electric Bills:** As a replacement for grid-tied properties (anywhere with access to power lines), solar power costs just a fraction of what you pay the utility company each month. A properly sized system can drop your electric bill to zero.
- **Remote power:** If you live in a remote location, it may be too expensive or impossible to run power lines to your house. Solar power systems generate energy when you cannot hook into the power grid.
- **Improve Property Value:** Homes equipped with solar systems sell for 3.74% more than equivalent homes without solar. Off-grid solar also enables you to buy affordable undeveloped property in rural areas.

## Cons

- **High up-front cost:** Even small systems cost thousands, and full-scale systems for a family home can reach a 5-figure price tag. Though it pays for itself in the end, it can be prohibitively expensive to get started.
- **Storage is expensive:** Batteries are by far the most expensive part of a solar system. If you need them to store power (either off the grid or as backup for your grid-tied system), that will eat into your return on investment. They should be used out of necessity, or to provide peace of mind in areas with unreliable power.
- **Pollution in the form of electronic waste.** In recent years the electronics industry has gained notoriety for creating an endless stream of disposable products that make their way at life's end to developing countries, where poor people without safety gear cut and burn out valuable materials, spilling contaminants into their water, air, and lungs.

Solar modules contain some of the same potentially dangerous materials as electronics, including silicon tetrachloride, cadmium, selenium, and sulfur hexafluoride, and a potent greenhouse gas. So as solar moves from the fringe to the mainstream, insiders and watchdog groups are beginning to talk about producer responsibility and recycling in an attempt to sidestep the pitfalls of electronic waste and retain the industry's green credibility.

How does the solar system work?

Another one of the fundamentals of solar energy is understanding the simplicity of how the process works. Solar energy is produced by capturing radiant light and heat from the sun and then converting it into energy to power homes, businesses, tools and machinery.

Electricity is generated during peak periods like the hot afternoons when the demand is highest.

There are different kinds of systems that can be designed to collect and store solar energy but the most common installation is known as an active solar power system.

An active system uses a mechanism, such as the solar panels one sees on a roof, to capture sunlight and generate power. Solar panels are made up of photovoltaic (PV) cells that capture sunlight particles called photons.

Using a semiconducting material such as silicon, the PV cells then convert the photons into useable direct current (DC) electricity.

An inverter connected by wires to the panels turns that direct current (DC) into alternating current (AC) electricity and sends it to the breaker box panel in your

home or business to power your lights, computers and other appliances. The fundamentals of solar energy systems are simple.

Depending on how much power your system generates – which is impacted by both its size and your location – you may still need to be tied into your local utility company’s power grid. That way, you can access any additional power you still might need or you can sell any excess energy you generate into the grid for others to use. This concept is referred to as “net metering” – another one of the fundamentals of solar energy. Net metering allows residential and commercial customers who generate their own electricity from solar power to feed electricity they do not use back into the grid.

### Types of solar systems

There are three main types of residential solar electric power systems

1. Grid inter-tied
2. Grid inter-tied with battery backup
3. Off-grid.

These three broad types vary in how closely connected they are to the traditional power utility infrastructure, known as the grid.

Each type has strengths that determine how suited they are to your needs.

#### 1. Grid Inter-Tied Residential Solar Power Systems

A grid inter-tied solar power system is directly connected to the home and to the traditional electric utility grid. Grid inter-tied systems allow the homeowners to get power from either the home electric system or the utility grid. Switching between the residential system and the grid is seamless.

The prime advantage of this type of system is the ability to balance the system production and home power requirements. When a grid inter-tied system is producing more power than the home is consuming, the excess can be sold back to the utility in a practice known as net metering. When the system is not producing sufficient power, the home can draw power from the utility grid.

Grid inter-tied systems are the lowest cost type of residential solar electric system, due to having fewer required components.

## 2. Grid Inter-tied Residential Solar Power System with Battery Backup

A grid inter-tied solar power system is also connected to the traditional utility power grid and adds battery-backup to the system. The addition of a battery backup enables the system to balance production and demand and protects against power outages.

Solar electric system production depends on the available sunlight. When sunlight is abundant, production can exceed demand. When production exceeds demand, the excess power can charge the batteries, which store the electricity. When the system is producing less electricity than demanded by the home, the batteries can make up the shortfall.

Grid Inter-tied systems are also connected to the utility power grid. This enables the homeowners to draw from the grid during periods of excess demand and to sell power to the grid when there is excess production.

While grid inter-tied systems offer more flexibility, they are not without disadvantages. Charging and discharging batteries reduces the overall efficiency of the system and these systems are more complex to design and install and therefore more expensive.

### 3. Off Grid Solar Power Systems

An off-grid residential system is completely disconnected from the traditional electric power grid. Without a connection to the utility grid, batteries are essential to balance periods of excess production and excess demand.

To protect against shortfalls of power when the solar system is under-producing and the batteries are discharged, an electric generator is usually added to the system. The generator is used as a power source during periods of prolonged excess production or unusual demand.

#### a. Standalone Solar System

A free standing or Stand Alone PV System is made up of a number of individual photovoltaic modules (or panels) usually of 12 volts with power outputs of between 50 and 100+ watts each. These PV modules are then combined into a single array to give the desired power output.

A simple standalone PV system is an automatic solar system that produces electrical power to charge banks of batteries during the day for use at night when the sun's energy is unavailable. A standalone small scale PV system employs rechargeable batteries to store the electrical energy supplied by a PV panels or array.

Standalone PV systems are ideal for remote rural areas and applications where other power sources are either impractical or are unavailable to provide power for lighting, appliances and other uses.

In these cases, it is more cost effective to install a single standalone PV system than pay the costs of having the local electricity company extend their power lines and cables directly to the home.

A standalone photovoltaic (PV) system is an electrical system consisting of an array of one or more PV modules, conductors, electrical components, and one or more loads. But a small-scale PV system does not have to be attached to a roof top or building structures for domestic applications, they can be used for camper vans, RV's, boats, tents, camping and any other remote location. Many companies now offer portable solar kits that allow you to provide your own reliable and free solar electricity anywhere you go even in hard to reach locations.

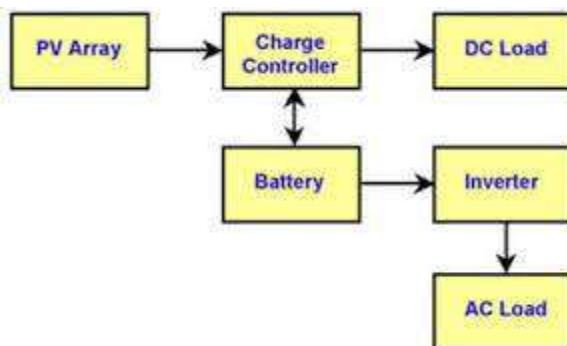

## Figure 1: Standalone PV System

While a major component and cost of a standalone PV system is the solar array, several other components are typically needed. These include:

- **Batteries:** Batteries are an important element in any standalone PV system but can be optional depending upon the design. Batteries are used to store the solar-produced electricity for nighttime or emergency use during the day.

Depending upon the solar array configuration, battery banks can be of 12V, 24V or 48V and many hundreds of amperes in total.

- **Charge Controller:** A charge controller regulates and controls the output from the solar array to prevent the batteries from being over charged (or over discharged) by dissipating the excess power into a load resistance. Charge controllers within a standalone PV system are optional but it is a good idea to have one for safety reasons.
- **Fuses and Isolation Switches:** These allow PV installations to be protected from accidental shorting of wires allowing power from the PV modules and system to be turned “OFF” when not required saving energy and improving battery life.
- **Inverter:** The inverter can be another optional unit in a standalone system.

Inverters are used to convert the 12V, 24V or 48 Volts direct current (DC) power from the solar array and batteries into an alternating current (AC) electricity and power of either 120 VAC or 240 VAC for use in

the home to power AC mains appliances such as TV's, washing machines, freezers, etc.

- **Wiring:** The final component required in and PV solar system is the electrical wiring. The cables need to be correctly rated for the voltage and power requirements. Thin telephone or bell wire will not work!

First, standalone solar power requires the sun. If the area does not receive a generous amount of direct sunlight each day the photovoltaic, system may not be able to produce enough energy when needed or to charge the batteries.

Excessive shading from surrounding objects and cloud cover are two things that can affect the amount of direct sunlight that strikes the solar panels so identifying potential shading areas, location and orientation of the PV panels or array are important factors to consider.

Other factors include sufficient land/area space available, average wind speed, system budget and importantly system efficiency.

For example, system efficiency equals (power out)/ (power in), the overall system efficiency is the product of component efficiencies, so a solar photovoltaic panel may be capable of delivering 100W peak power into the system, but due to losses in the cabling, inverter, controller etc., the PV system

may only provide 60 watts or 60% of its capacity at the output with the rest being lost.

### Important factors in having a standalone PV system

Firstly, you need to become very aware of how and when you use electricity.

Solar panels only create electricity while the sun is shining on them so it may be necessary to store enough electricity to get you through one or two days of cloudy weather.

In this case, solar electricity becomes a valuable resource, you will not want to live without it, but you will not want to waste it, either. Try reducing energy demand through energy efficient measures.

Purchasing energy saving appliances and LED lights, for example, will reduce your electrical demand and allow you to purchase a smaller standalone PV system to meet your actual energy needs. Energy efficiency allows you to start small and then add on, as your energy needs increase.

Secondly, while a standalone PV system is not a complicated system to install or run compared with other forms of off grid electrification devices, wind turbines, hydro-electric etc. solar PV systems still require regular maintenance that is not normally associated with standard grid connected mains power.

You may want to become familiar with how your standalone solar power system works, and what kind of daily or weekly maintenance is required.

All the systems components have to be checked and cleaned on a regular basis to make sure that the system is running optimally and like many other off grid systems, PV systems require some basic electrical knowledge in order to be able

to install and maintain them in an effective manner and to diagnose any problems so become an expert of your system.

There are many advantages of a standalone PV system some include low maintenance, low upkeep cost, no waste or byproducts, and easy expansion by using multiple solar panels and batteries.

The disadvantages include high initial investment, especially for the photovoltaic panels and deep cycle lead acid batteries, reliance on the sun, and the possible danger from battery acid and fumes associated with most forms of renewable energy.

## Chapter 3: Solar Energy and Socio-Economic activities

### Solar and economic activities

With many economies facing slow growth prospects, policy makers increasingly see chances for greater income, improved trade balances, industrial development and job creation through renewable energy deployment. However, detailed evidence on these effects remains limited.

*The Socio-economic Benefits of Solar*, an ‘econValue’ report from the International Renewable Energy Agency (IRENA), sheds light on the value-creation potential of solar, in particular, as a crucial first step for continuing research and analysis. Produced in cooperation with the Clean Energy Ministerial, the report presents a conceptual framework for analyzing macroeconomic, distributional, energy-related and other effects of large-scale renewable energy deployment.

Value can be created in each step of manufacturing, from sourcing of raw materials and manufacturing of components to final assembly and installation. The presence of other industries semi-conductors (for solar photovoltaics), or glass making (for concentrated solar power) – facilitates the development of local renewable energy manufacturing.

Upgrading power grids to integrate renewables also contributes to broader value creation, while operation and maintenance of renewable energy facilities creates long-term jobs for plant monitoring, equipment inspections and repair services.

With the emergence of a local renewable energy industry, numerous opportunities for domestic value creation arise along all segments of the value chain.

### Solar and social activities

With the use of solar, we reduce indoor air pollution, which is caused by use of kerosene or paraffin to give light at night. The toxic fumes can block the airways leading to respiratory complications. They also cause eye infections especially in young children who develop cognitive disorders such as amnesia, dementia and developmental disorders.

With solar we also see improved learning opportunities for students in the rural setting where they are able to read for longer hours at night as opposed to when using kerosene, which is expensive.

Jobs have been created by the solar system industry. From production and manufacturing to installation and maintenance. This has helped bridge the unemployment gap as the youth are absorbed in the various positions.

Empowerment especially in women: One of the major ways in which renewable energy can empower rural women is by transforming the rural education scenario, powering more schools and thereby widening access to quality education. Majorities of schools still lack access to electricity, and this is one of the primary reasons for low attendance, and often drop outs, especially amongst girls. Electrified village schools have historically witnessed lower dropout rates, higher test scores, and higher proportions of girls entering secondary education.

If one changes the way education is imparted, this leads to students, especially girls forming better, newer ideas.

## **Chapter 4: Solar Appliances.**

The charge controller will charge the batteries when there is sufficient power to charge them. Any extra power produced by the solar panels will be sent to the inverter. When the batteries are fully charged, the charge controller will cut off the charge going to the batteries except for a small float charge meant to keep the batteries fully charged.

With sufficient sunlight, the solar panels provide electricity to the system. Power provided to the solar charge controllers from the solar panels will be used to recharge the batteries. The amount of voltage, known as the nominal voltage, needed to charge the batteries rises as the batteries charge. As a result, the charge controller will increase its output voltage as the level of charge in the batteries rises. When the batteries are fully charged, the charge controller maintains a trickle charge to hold the batteries at their full charge.

When the sun is not shining, the charge controller will block current from flowing from the batteries to the solar panels. This prevents the batteries from discharging into the solar panels.

To keep things simple, imagine we are charging a 12-volt battery. A 12-volt solar panel is used to charge a 12-volt battery. However, that solar panel will actually have an output that is closer to 18 Volts at maximum power when there is a load presented by the batteries. That is because batteries need a higher voltage source to accept a charge. If the charge controller supplied only the battery's rated charge, the battery would not charge.

In the afternoon, when the power output from the solar panels declines, the charge controller will isolate the battery from the solar panels to prevent the

batteries from discharging into the panels. If a float charge is desired, it will come from grid power.

### Different types of solar appliances

Below is a table showing different solar appliances and the appliances they replace as part of Environmental conservation and protection

<b>Solar appliances</b>	<b>Normal appliances</b>
Solar lamps	Kerosene lamps
Solar water pumps	Electric water pumps
Solar dryers	Electric dryers
Solar hot water	Instant hot water shower

Table 1: Comparison between Solar Appliances and Normal Appliances

### Pico solar system

It uses small compact and lightweight solar photovoltaic panels to generate just a few watts of power in a wide range of small and portable applications.

Pico solar systems are much smaller and cheaper than traditional solar systems but have the potential to provide useful amounts of electrical power to charge the increasing number of low power gadgets such as calculators, toys, cameras, mp3 players, cell phones, tablets, and other portable electronic devices etc., as well as a variety of chargers all use Pico solar cells to charge batteries.

Photovoltaic solar cells now come in various shapes and sizes and *Pico solar*, “Pico” meaning very small, is an emerging new category, along with micro solar and Nano solar, of low power solar photovoltaic electric system which has a lot

of potential to power low power LED lighting to light up millions of homes in much the same way that cell phones have connected people and communities around the world.



Figure 2: Pico Solar Light



Figure 3: Pico Solar Battery Charger

Solar energy is about reducing our reliance on fossil fuels and Pico solar systems can be used to provide power to a wide range of applications. As their name suggests, Pico solar systems are much smaller than traditional solar home systems generating just a few watts to power light emitting diode (LED) lights and a wide range of energy efficient portable devices.

Pico solar systems come in a range of shapes and sizes, with a typical system being made up of the following components:

- A Pico PV solar module usually less than 20 watts-peak to capture the sun is light to generate the electricity.
- Rechargeable dry-cell battery or batteries of less than 12 volts to store the solar power for use when needed.
- Some form of charge control and battery management circuitry to protect the battery or batteries from overcharging or deep discharging.

- Power plugs and cables to connect and power devices such as phones, tablets and external lights.
- Internal lighting as most Pico chargers now come with small highly efficient LED lighting built-in as standard.

## **Chapter 5: Operation and Maintenance of Solar System.**

It is important that regular maintenance be carried out on your solar panel system. Undertaking regular maintenance will ensure your solar panel system is operating safely, correctly and efficiently.

Over time, dust and debris will build up on your solar panels, which may compromise the performance of your solar panel system. In addition, water and moisture seepage, vermin, hail, wind and sunlight can all cause damage or deterioration to your system.

By ensuring regular routine maintenance is undertaken, you can ensure your solar panel system is safe for everyone living in the premises, along with electrical workers working on the distribution network. Routine maintenance will also ensure system performance is maintained, allowing you to maximize savings on your power bills for many years.

Maintaining your solar panel system involves much more than simply cleaning your solar panels. Regular maintenance of your solar panel system should ensure:

- solar panels are clean, secure and free of defects
- no parts have deteriorated/corroded
- vents are free of debris
- switches do not have any defects
- wiring has not been damaged/has not deteriorated
- electrical checks to ensure all components are operating as intended
- confirming fittings and cables are securely attached

- reviewing the inverter display panel for recorded faults
- checking that access to the isolator switches has not been impeded, and/or
- Making sure the emergency procedures for shutdown and isolation are clearly displayed.

The regular maintenance will help solve problems that might arise such as damaged wiring, weak batteries, rust and obstructions.

## **Chapter 6: Solar system as a renewable source of energy in relation to climate change and environmental degradation.**

Solar energy is a renewable free source of energy that is sustainable and very inexhaustible, unlike fossil fuels that are finite. It is also a non-polluting source of energy and it does not emit any greenhouse gases when producing electricity.

With using other sources of energy such as wood fuel, we cut down trees and reduce the forest cover. Forests are carbon sinks therefore without them then there is an increase in greenhouse gases, which produce the greenhouse effect, which leads to global warming that is the root of climate change. Forests are also water catchment areas. With reduced forest cover, we also experience a reduction in the amount of available water, which is also another serious aspect of climate change.

Therefore, solar energy is a good alternative on the road to environmental protection and conservation

Solar energy helps to preserve the quality of health of human beings and that of the environment.

## **Conclusion**

Solar energy is a clean source of energy, which should be considered as a viable option compared to kerosene, which is a lighting option, wood fuel as a cooking fuel, and electricity, which is an expensive source of energy.

We see that it reduces indoor house pollution reducing the number of deaths relating to this to zero. We also see that it reduces respiratory diseases infections such as bronchitis and reduces the increase of already existing diseases such as asthma.

We need to adopt this form of energy as it is cheaper, inexhaustible and readily available even though the initial installation costs are high, the subsequent advantages outdo the initial costs.

With proper recycling of the solar panels, then this can be the best option yet as it also reduces the amount of greenhouse, gases in the atmosphere, which are produced by combustion of wood fuel.

We should stop our over dependence on the fossil fuels as they are quickly running out, they are not sustainable and pollute the environment.

## References

Wholesale Solar, Solar Power. Retrieved <https://www.wholesalesolar.com/solar-information/solar-power-101>

Wholesale Solar, The Pros and Cons of Solar Energy. Retrieved <https://www.wholesalesolar.com/blog/pros-cons-solar>

Venture Solar, The Basic Fundamentals of Solar Energy. Retrieved <https://venturesolar.com/blog/the-basic-fundamentals-of-solar-energy/>

Alternative Energy Tutorials, Standalone PV System. Retrieved <https://www.alternative-energy-tutorials.com/solar-power/stand-alone-pv-system.html>

International Renewable Energy Agency, The Socio-economic Benefits of Solar and Wind Energy. Retrieved <https://www.irena.org/publications/2014/May/The-Socio-economic-Benefits-of-Solar-and-Wind-Energy>

Deya, F, Rural Schools in Kenya to Adapt Solar Energy for Better Learning. Retrieved <https://www.talkafrica.co.ke/rural-schools-in-kenya-to-adapt-solar-energy-for-better-learning/>

<https://freedomforever.com/how-solar-energy-storage-systems-work/#:~:text=With%20sufficient%20sunlight%2C%20the%20solar,rises%20as%20the%20batteries%20charge.>

Infinite Energy. Retrieved <https://www.infiniteenergy.com.au/how-do-solar-batteries-work/>

Alternative Energy Tutorials. Retrieved <https://www.alternative-energy-tutorials.com/energy-articles/pico-solar-systems.html>

Renewable Energy Target, Solar Panel System Maintenance. Retrieved

<http://www.cleanenergyregulator.gov.au/RET/Pages/Scheme%20participants%20and%20industry/Individuals%20and%20small%20business/Solar-panel-system-maintenance.aspx>

Gies. E, Are Solar panels the next E- waste. Retrieved

<https://www.theguardian.com/environment/2010/sep/03/solar-panels-ewaste>